

4.5" RECESSED FLUSH TRIM
CONCEALED RECESSED ARCHITECTURAL DOWNLIGHT



**A ceiling plane that is uninterrupted,
unobtrusive,
unbelievable.**

dreamscape
LIGHTING MFG., INC.

4.5" RECESSED FLUSH TRIM AND HOUSINGS

CONCEALING THE FIXTURE INTO THE CEILING



Our patented perforated mudding collar enables a seamless installation.

Interior recessed lighting has reached a new level of sophistication with the development of Dreamscape Lighting's Flush Trim. The requirement of an uninterrupted ceiling space that barely reveals the recessed light sources is now possible via Dreamscape's patented Flush Trim mudding collar and installation procedure.

US Design Patent
Des 427,368
Flush Trim Patent
US 6,474,846,B1

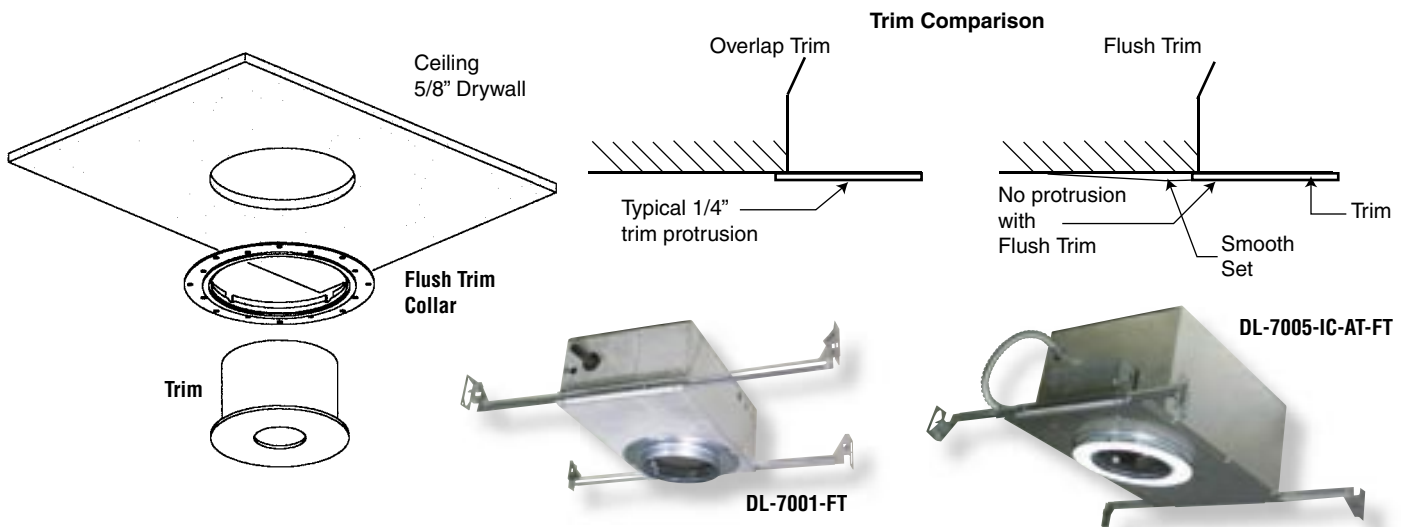

Installation:

Installation is clean and easy with the patented Flush Trim Finishing Kit (request on order).

DL-7001-FT

Non-IC Housing shown with optional Flush Trim Collar A installed.

- Shallow housing fits into 2 x 6 ceiling joist.
- Removable top for above ceiling lamp replacement.
- ETL listed 50W max.
- Quiet toroidal transformer.

DL-7005-IC-AT-FT

IC Airtight Housing shown with optional patented Flush Trim collar installed.

- Quiet toroidal transformer.

TRIMS AND ORDERING INFORMATION

Utilizing either our IC Airtight or Non-IC housing and the patented Flush Trim Mounting Collars, trim choices range from pinhole downlights to an adjustable wall washer.



The Flush Trim collar creates the illusion that the recessed trim is flush with the ceiling. The look of the standard overlapping flange has been eliminated.

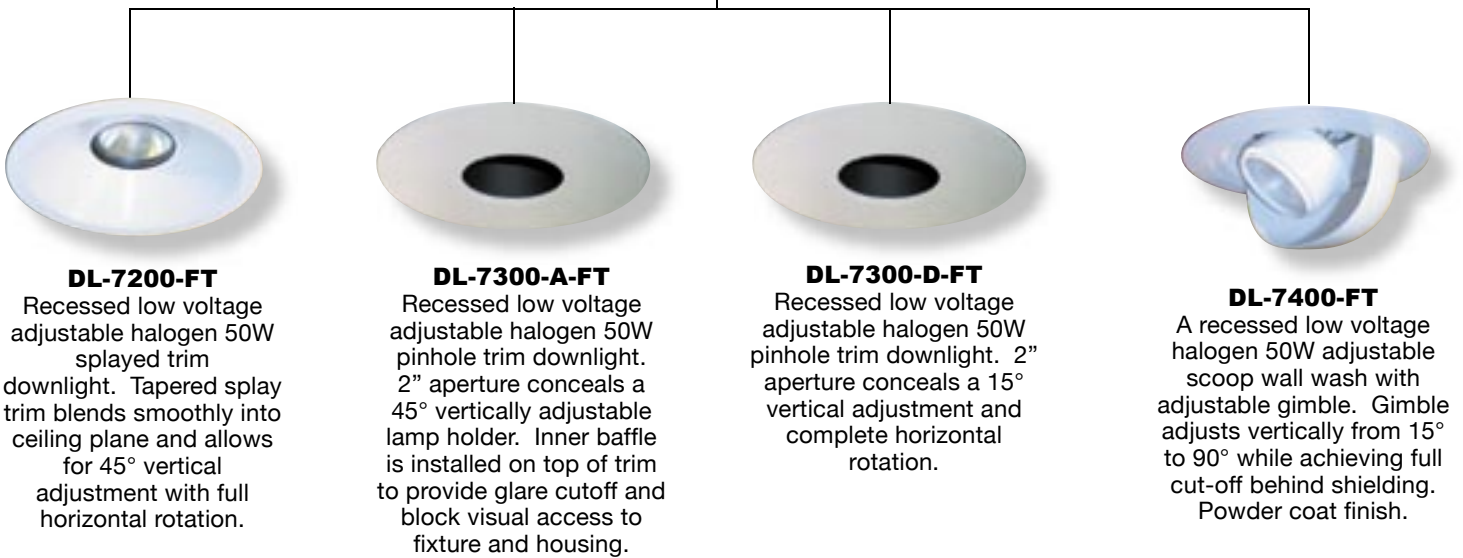

| Housing No. | Description | Dimensions | Trim No. | Description | Lamp | Dim. | Trim Finishes |
|------------------|--|----------------------------|-------------|---------------------------------|-------------|----------------|--|
| DL-7001-FT | Non-insulated ceiling | 4-1/2" x 7-5/16" x 12-1/2" | DL-7200-FT | Splayed trim 45° adj. downlight | 50W MR16 | 5-3/8" O.D. | 4 - White powder coat 7 - Custom powder coat finish (consult factory) |
| DL-7005-IC-AT-FT | Airtight for insulated ceiling | 7" x 10" x 17" | DL-7300A-FT | 45° adj. pinhole trim downlight | | | |
| FTFK | Flush Trim Finishing Kit | | DL-7300D-FT | 15° adj. pinhole trim downlight | | | |
| | Standard flush trim collar is designed for 5/8" drywall. Contact factory for a custom ceiling thickness Flush Trim collar. | | DL-7400-FT | 15° - 90° adj. scoop wall wash | | | |

- All Dreamscape housings are ETL listed for damp location and feed through wiring.
- All units are powered by a remarkably quiet toroidal transformer.
- A 1/2" plaster lip is supplied with centerline notches for precise fixture alignment.
- No above ceiling access is required.
- Supplied with adjustable locking hanger bars with nail tabs.

*“accentuate your interior
with seamless illumination
by Dreamscape Lighting”*

dreamscape
LIGHTING MFG., INC.

Design Credit:
Glenn Johnson, IALD
Photography:
Andrew Mitchell

5521 W. Washington Blvd. • Los Angeles, CA 90016
Phone: 323-933-5760 • FAX: 323-933-3607
info@dreamscapelighting.com • www.dreamscapelighting.com
Specifications subject to change without notice.