

LUNAR DIRECTIONAL LIGHTING - SURFACE MOUNT

A SOLID BRASS COMPACT ACCENT LUMINAIRE

Lamping: MR-11, MR16 or LED

Cat. No: DL-102 (Lunar I) - _____ - _____ - _____ - _____ - _____
 DL-104 (Lunar II) - _____ - _____ - _____ - _____ - _____
 DL-133 (Lunar III) - _____ - _____ - _____ - _____ - _____

Type: _____ / Project: _____

Date: _____

Fixture Description:

The LUNAR SERIES have been designed to provide discreet accent illumination. Made from solid brass they are extremely durable and compact, allowing them to provide maximum controlled illumination in a small decorative housing. The fixtures are available in many hand etched metal finishes. These finishes age gracefully as the brass fixture weathers naturally in the landscape environment.

Specifications:

Construction: Solid brass construction with optional glare shield and light control accessories. Also available as a canopy mount or ground mount accent light (See spec sheet for Lunar Post and Stake Mount).

Lamp: Lunar I: MR-16/FG (with lens): 35W / 50W, or 3 watt 12 volt LED 2700K (other color temps available). Lunar II: 20W / 35W MR-16/FG (with lens), or 3 watt 12 volt LED 2700K. Lunar III: 20W MR-11/FG or 3 watt 12 volt LED 2700K (other color temps available).

Elec. Requirements: Requires remote 12 volt source.

Mountings: Yoke mount, 1/2" NPT

Labels:

ETL Listed Damp Location - Conforms to UL1598, Certified Canada CSA 22.2

Options:

Diffusers: Diffusion and linear lens. See ordering chart below.

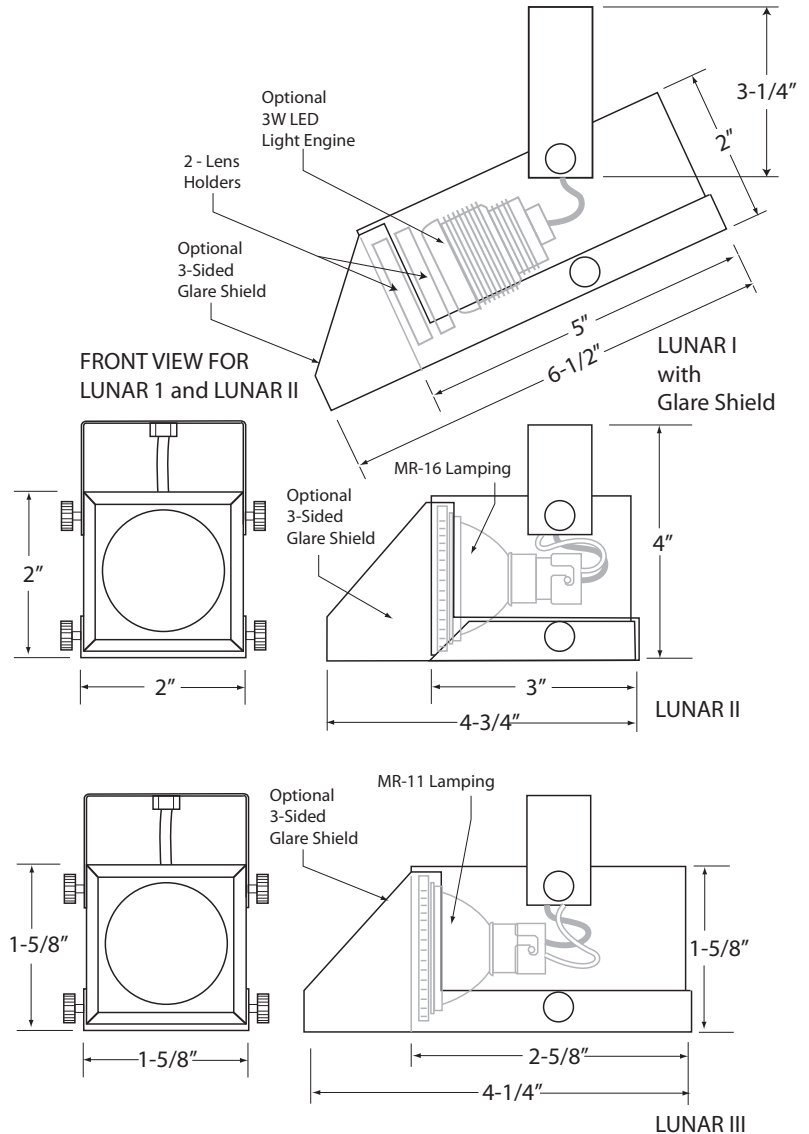

Cat. Number	Description
DL-102	Lunar I (with clear lens & yoke)
DL-102 LED	Lunar I (above for LED lamping)
DL-104	Lunar II (with clear lens & yoke)
DL-104 LED	Lunar II (above for LED lamping)
DL-133	Lunar III (with clear lens & yoke)
DL-133 LED	Lunar III (above for LED lamping)
DL-210	3-sided glare shield for Lunar I & II
DL-212	14" stake for Lunar I & II
DL-213	30" stake for Lunar I & II
DL-215	3-sided glare shield for Lunar III
DL-216	14" stake for Lunar III
DL-217	30" stake for Lunar III
DL-230	2" round canopy for all fixtures
DL-231	3-3/4" round canopy for all fixtures
DL-235	5" round canopy for all fixtures
DL-224	Honeycomb Louver
DL-226	Diffusion lens for all fixtures
DL-227	Linear lens for all fixtures
DL-228	Clear lens for all fixtures - standard

Finishes: 1) Verdè 2) Satin Nickel 3) Copper Bronze 4) White* 5) Ancient Bronze 6) Brass Bronze 7) Custom 8) Copper Plate 9) Ancient Verdè 10) Grey Broze 11) Rust Brown* 12) Black* 13) Pewter

Lamps: Lunar I: 20, 35, or 50W bi-pin MR-16 FG. Lunar II: 20 or 35W bi-pin MR-16 FG. Lunar III: 20W bi-pin MR-11 FG
 Lunar I, II or III: 3W LED 2700K Spot, or 3W LED 2700K Flood

* Powder coat finish

To Form a Catalog Number:	Part No.	Optics 1	Optics 2	Mounting	Finish
	DL-102	210	224	212	5
Which Specifies:	DL-102 LED DL-104 DL-104 LED DL-133 DL-133 LED	Glare Shield for Lunar I & II 215 Glare shield for Lunar III	Honeycomb Louver	14" Stake (Lunar I & II)	Ancient Bronze