

Project:

DLED-5100 Series Specification Sheet

Date:

LED 35,000 Hour Dimmable Light Strip for Dry Locations
190 Lumens per Foot - 3.9 Watts per Foot - CRI 75

Type:

Cat. No. DLED-5100 - _____ - _____ - _____ - _____ - _____

Fixture Description:

The DLED 5000 is a continuous line of dimmable led's soldered to a rigid PC board. They have been designed to give a long consistent color over the 35,000 hr lamp life, because of good thermal management of the SMD's and quality phosphors used in production. This LED lightsource provides a soft even glow at a huge energy savings over incandescent or halogen. A 50,000 hr. lamp life greatly reduces maintenance.

Construction:

16 LED diodes per foot soldered to a rigid PC board with jumper wire and feed wire pre-wired and attached. For lengths from 75" to 96", two strips are connected by a 1" flex wire joiner.

Electrical:

24 Volt AC. 3.9 Watts per foot. 190 lumens per foot. CRI 75. Dimmable.

IMPORTANT: LED strips are to be fed from UL Listed Class II magnetic transformers.

Mounting:

Mounts into coves or other surfaces with screws and/or double stick tape.

Applications:

- Coves • Light Pockets • Accent Lighting
- Cabinet Lighting • Undercabinet Lighting
- Reveal Molding

LED Specs:

Voltage:	24 Volts AC
Watts:	3.9 Watts per foot
Lumens per foot:	190
Color Temp.:	2700K, 3000K, 3500K
Beam Spread:	120°
Max. Run:	8'
Max. Single Length:	6'
Mounting:	Screw or Dbl Stick Tape
Warranty:	3 year / 35,000 Hr.

Connectors

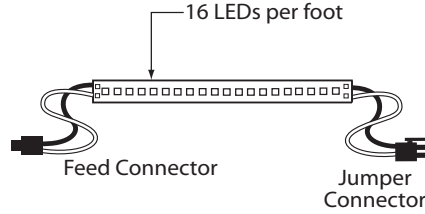

End View

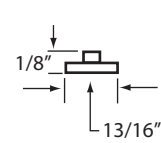

2 Separate Lengths Joined with 1" Flex Wire for LED Strips from 75" - 96"

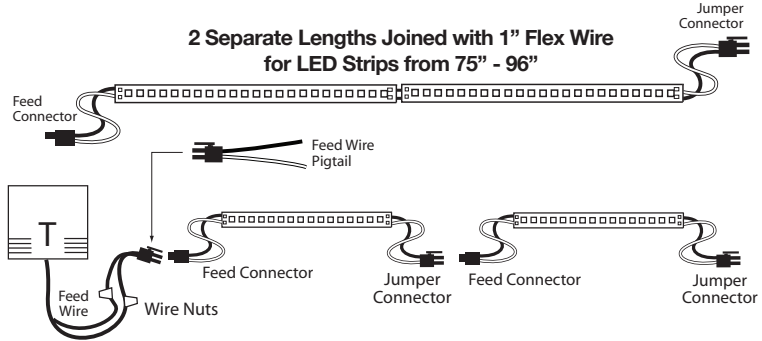

Mounting:

Mounts into coves or other surfaces with screws and/or double stick tape.

Applications:

- Coves • Light Pockets • Accent Lighting
- Cabinet Lighting • Undercabinet Lighting
- Reveal Molding

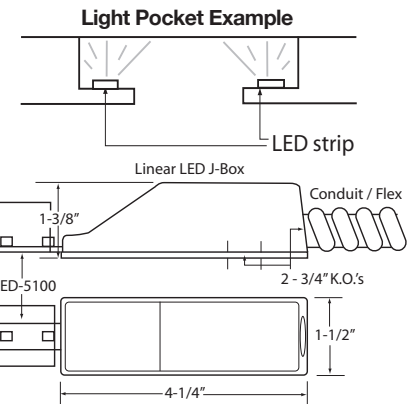
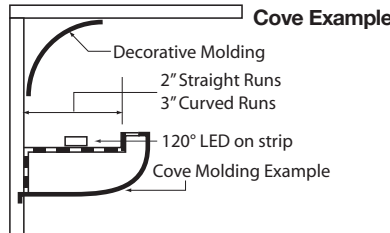

Secondary Wire Specification

Max. Load:	50 Watts
Max. Distance:	50 Feet
	16 AWG 2/C Type CM-CL2
	ETL-CM CL3
	Standard copper conductor

DL-CFB-5100 Conduit Feed Box

Model No.	LED Length	Feed Wire Length	Jumper Wire Length	Pigtail Length**	Color Temp.
DLED-5100	3", 6", 9", 12", 15", 18", 21", 24", 27", 30", 33", 36", 39", 42", 45", 48", 51", 54", 57", 60", 63", 66", 69", 72",	1.5", 3"	None* (0), .75"	0, 3"	2700K
	See note for LED lengths over 72"	6", 12"	1.5", 3", 6", 12",	12"	3000K
	75", 78", 81", 84", 87", 90", 93", 96"	18", 30"	18", 30"	36"	3500K
		Custom	Custom	Custom	

NOTE: All LED lengths 75" - 96" are made up of 2 separate units joined together by a 1" flex wire.

FOR CURVILINEAR APPLICATIONS - SPECIFY .75" JUMPER WIRE LENGTH

*NOTE: You can specify "0" for no jumper wire on the end.

** NOTE: 1 pigtail per run (specify 3", 12", 36", or Custom)

LED Length	Feed Wire Length	Jumper Wire Length	Pigtail Length	Color Temp.
------------	------------------	--------------------	----------------	-------------

Ordering Example:

DLED-5100 - 12" - F3" - J3" - P3" - 3000



©2011 Dreamscape Lighting Mfg., Inc.
 5521 W. Washington Blvd. • Los Angeles, CA 90016
 Phone: 323-933-5760 • FAX: 323-933-3607
 info@dreamscapelighting.com • www.dreamscapelighting.com
 Specifications subject to change without notice



100511_DLED5100

DLED-5100 LED Strip Installation Instructions

1. Create a dry, flat, non-conductive platform for the DLED-5100 LED Strip to be mounted to.
2. Install a class II magnetic transformer or driver to provide 24 volts AC or DC power to the DLED-5100 LED Strip. Power requirements are 3.9W per foot.
3. Run feed wire from the transformer to the LED location. Do not exceed a 5 percent voltage drop (see back on Calculating Voltage Drop).
4. Connect a Molex® inter-connector pigtail assembly to the feed wire from the transformer (see diagram at right).
5. Place feed connector end of DLED-5100 close enough to the pigtail assembly Molex® connector. See diagrams at right.
6. Mount DLED-5100 board to a dry, non-conductive, flat surface by using the supplied #4 x 3/8 Round Phil/Pan wood screws. As an alternative, you may use Tesa #51970 Double Stick Tape (or equivalent), which can be ordered separately. When using Tesa tape, if the board is shining down, it is recommended to use at least one screw per foot.
7. When DLED-5100 is set in place, plug Molex® connectors together.

NOTE: Do not bend DLED-5100 to break solder joints. No single run may exceed 8 feet from one end feed.

DIMMING: Magnetic transformers may be dimmed with appropriate low voltage dimmers by others.

CAUTION: Do not exceed a maximum connected load of 96 watts or 24' of DLED-5100 LED Strip per 4 amp breaker.

Instructions for Field Cutting DLED-5100 Strips

If you find that the lengths of DLED-5100 strips that you ordered are too long, it is preferable to return them to the factory and re-order the correct length so that you do not jeopardize the product warranty. If time is a problem and if you are willing to jeopardize the warranty, you may field cut the strips in the following manner:

1. The DLED-5100 strips may be cut at 3" increments. When measuring from the end, you will find a set of four solder pads. Using a sharp tool, cut exactly between the four pads, leaving two on either side.
2. Seal the end of the board using Silicone Conformal Coating.

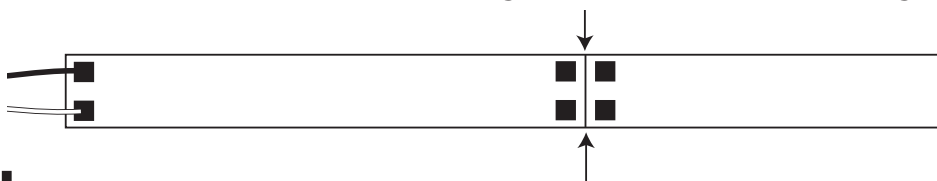

Silicone Conformal
Coating: 422A-340G
Mfg: MG Chemicals
or equal:
[http://www.
mgchemicals.com/
products/422a.html](http://www.mgchemicals.com/products/422a.html)

Electrical Data Sheet

Model No.: DLED-5100
Voltage: 24 Volts AC/DC
Wattage: 3.9 Watts per Foot
Maximum Continuous Length: 6 ft.
Maximum Run from One Feed: 8 ft.

Cutability: Board may be cut on 3" increments between solder joints. All cut ends must be sealed with conformal coating.
Mounting: Use supplied mounting clips or #4970 or 51970 Tesa manufactured double-stick tape (or tape of equal durability).

CAUTION: DO NOT INSTALL DIRECTLY ONTO METAL

WARNING: Solid state transformers may not be compatible with our LED products. Recommended power supplies: Use either approved magnetic transformers or approved LED electronic drivers.

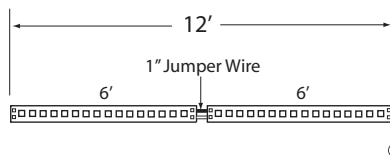
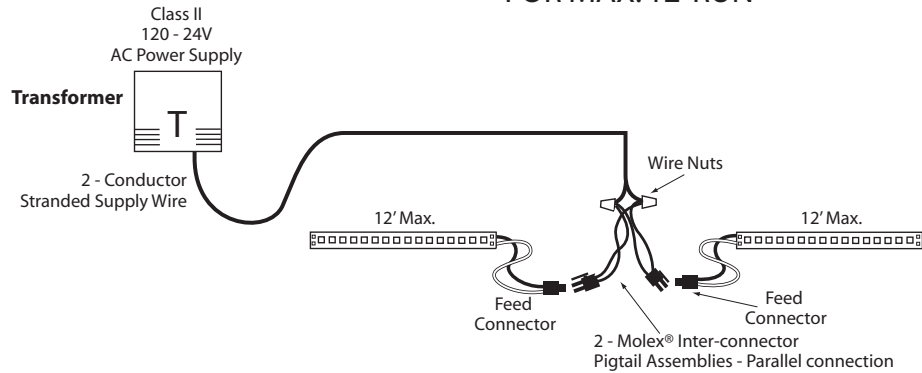
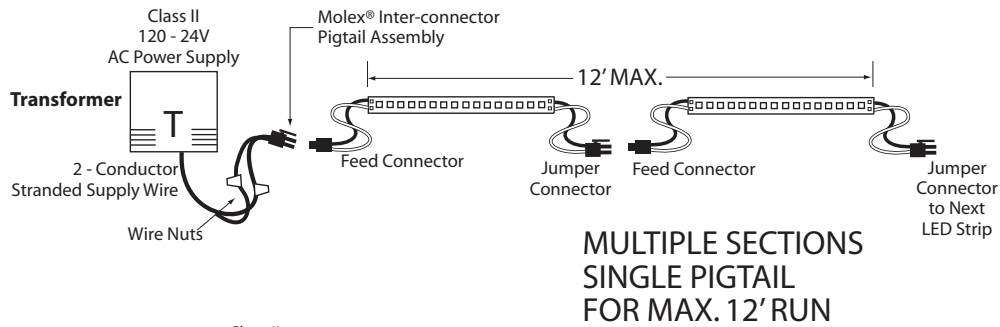
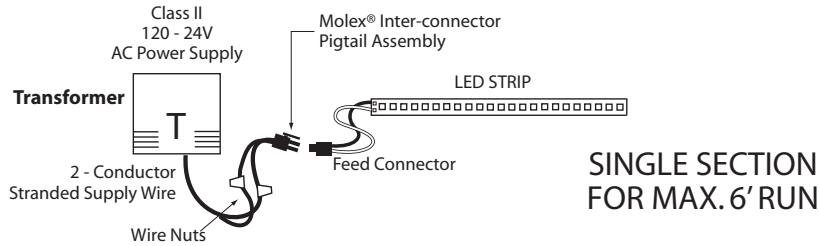

EXAMPLE: A 12' LENGTH IS MADE OF 2 - 6' LED STRIPS CONNECTED TOGETHER WITH A SHORT JUMPER WIRE.

Calculating Voltage Drop

The chart below can be used to maintain the proper voltage to your fixtures. Do not exceed a 5% voltage drop (1.2 volts for 24 volts) for full lamp output.

$$VD = (P \times K \times L \times I) \text{ divided by CM}$$

- VD = VOLTAGE DROP
- P = PHASE OF CIRCUIT (2 for single phase)
- K = RESISTANCE OF CONSTANT (12.9 for copper @75C)
- L = ONE-WAY LENGTH OF CIRCUIT (in feet)
- I = AMPERAGE OF LOAD BEING SERVED
- CM= CIRCULAR MIL AREA OF THE CONDUCTOR

CM TABLE FOR VARIOUS WIRE SIZES

#10-CM	10,380	#12-CM	6,530	#18-CM	1620
#8-CM	16,510	#14-CM	4,110	#16-CM	2580

EXAMPLE (24 WATTS - 100 FEET - 24 VOLTS):

$$VD = \frac{P \times K \times L \times I}{CM} = \frac{2 \times 12.9 \times 100 \times 1}{6,530} = .39 \text{ VD}$$

For 24 Volt circuit do not exceed 1.2 VD

#12 WIRE

MAXIMUM RUN LENGTHS FOR THE FOLLOWING WATTAGES AT 24 VOLTS AND USING #12 STRANDED FEED WIRES, NOT EXCEEDING A 5% VOLTAGE DROP.

WATTS	MAX. DISTANCE IN FEET
8	200'
16	200'
24	200'
32	200'
40	175'
48	140'
54	130'
60	120'
66	110'
72	100'
80	90'
88	80'
96	70'

$$AMPS = \frac{WATTS}{VOLTS}$$

EXAMPLE:

$$\frac{24 \text{ WATTS}}{24 \text{ VOLTS}} = 1 \text{ AMP}$$

$$\frac{8 \text{ WATTS}}{24 \text{ VOLTS}} = .33 \text{ AMPS}$$

$$\frac{16 \text{ WATTS}}{24 \text{ VOLTS}} = .66 \text{ AMPS}$$